

Actuator for
smoke control dampers 90° ↺

- Torque 40 Nm
- Nominal voltage AC/DC 24 V
- Control: Open/close
- Damper rotation:
BE24: 14 mm form-fit
BE24-12: 12 mm form-fit



Technical Data

Electrical data	Nominal voltage	AC 24 V, 50/60 Hz / DC 24 V	
	Nominal voltage range	AC 19.2 ... 28.8 V / DC 21.6 ... 28.8 V	
	Switching thresholds	min. ON voltage	AC 19.2 V / DC 21.6 V
		max. OFF voltage	AC 6.5 V / DC 6.5 V
	Power consumption	motoring	12 W @ nominal torque
		holding	0.5 W
		for wire sizing	18 VA / I _{max.} 8.2 A @ 5 ms
	Auxiliary switch		2 x 1 SPDT
		Contact rating (contacts gold plate on silver)	1 mA ... 6 A, DC 5 V ... AC 250 V <input type="checkbox"/>
		Switching points	3° ↺ / 87° ↺ (referred to 0 ... 90° ↺)
Connecting cable	motor	1 m, 3 x 0.75 mm ² (halogen-free)	
	auxiliary switch	1 m, 6 x 0.75 mm ² (halogen-free)	
Functional data	Torque (nominal torque)	Min. 40 Nm @ nominal voltage	
	Blocking torque	dynamic	40 Nm
		steady-state	50 Nm
	Direction of rotation	Selected by mounting L/R	
	Angle of rotation	Max. 100° ↺ (incl. 5° ↺ mechanical overrun on each side)	
	Running time	<60 s for 90° ↺	
	Sound power level	Max. 62 dB (A)	
	Damper rotation	BE24	Form-fit 14 mm
		BE24-12	Form-fit 12 mm
	Position indication	Mechanical with pointer	
Service life	At least 10'000 cycles		
Working conditions	Protection class	III Safety extra-low voltage	
	Degree of protection	IP54 in all mounting positions	
	EMC	CE according to 89/336/EEC, 92/31/EEC, 93/68/EEC	
	Mode of operation	Type 1.B (according to EN60730-1)	
	Rated impulse voltage	0.8 kV (according to EN60730-1)	
	Control pollution degree	3 (according to EN60730-1)	
	Ambient temperature range	normal duty	-30 ... +50°C
		safety duty	See «Safety function» on page 2
	Non-operating temperature	-40 ... +80°C	
	Ambient humidity range	According to EN 60730-1	
Maintenance	Maintenance-free		
Dimensions / weight	Dimensions	See «Dimensions» on page 2	
	Weight	Approx. 2'700 g	

Subject to technical changes

Safety notes



- The actuator is not allowed to be used outside the specified field of application, especially in aircraft or in any other airborne means of transport.
- The actuator is adapted and mounted to the fire and smoke damper by the damper manufacturer. For this reason, the actuator is only supplied direct to safety damper manufacturers. The manufacturer then bears full responsibility for the proper functioning of the damper.
- Since very high values of torque are exerted on the damper spindle it is advisable to use steel of at least grade St50.
- The device may only be opened at the manufacturer's site. It does not contain any parts that can be replaced or repaired by the user.
- The device contains electronic and electrical components and may not be disposed of with the household waste. Observe local regulations and valid laws.

Product features

- Mode of operation** Open/Close control is effected by means of a 2-wire system. The actuator is overload-proof and therefore remain energized while stationary at the end-stops.
- Signalling** Two microswitches with fixed settings are installed in the actuator for indicating the damper end positions.
The position of the damper blade can be read off on a mechanical position indicator.
- Manual operation** The crank handle supplied with the actuator allows it to be operated manually. It also allows a functional test of the damper to be performed very easily.
- Standards and specifications** The design of the actuator is based on the following standards and specifications:
 - Draft DIN 18232, Part 6, Sept. 1992
 - Fire protection in industrial buildings
 - Smoke and heat extraction systems
 - Preliminary standard ÖNORM H 6029, May 1997
 - Ventilation systems
 - Fire smoke extraction systems
 - Extracts from:
 - CEN/TC191, 1996
 - prEN12101-8 (Smoke and heat control systems – Specifications for smoke control dampers)

Safety function The safety function is guaranteed within the temperature range shown in the diagram below which is based on standard ÖNORM H 6029 and DIN 18232.

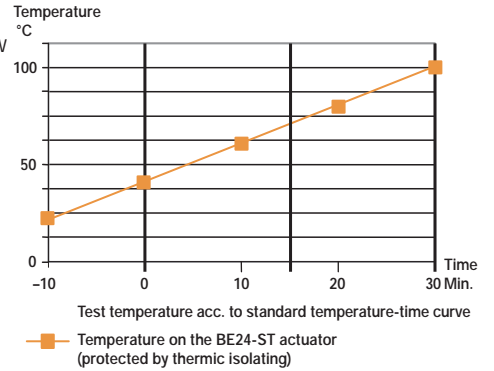

Electrical installation

Wiring diagram

Note

- Supply via safety isolation transformer
- Parallel connection of several actuators possible. Power consumption and switching thresholds must be observed!

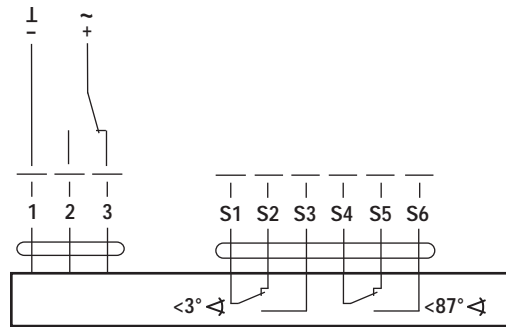

Dimensions [mm]

Dimensional diagrams

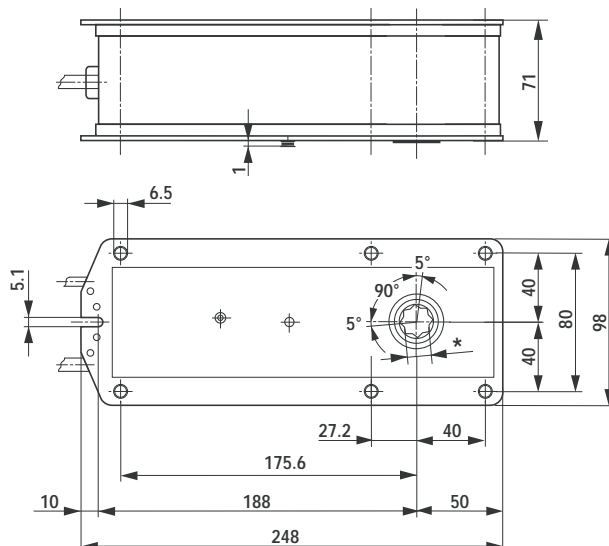

Type	Damper driver
BE24	Form-fit 14.2 mm
BE24-12	Form-fit 12.2 mm

Actuator for smoke control dampers 90° ↺, integrated in the SBSE-Control control and monitoring system.

- Torque 40 Nm
- Nominal voltage AC/DC 24 V
- Control: Open/close
- Damper rotation:
BE24-ST: 14 mm form-fit
BE24-12-ST: 12 mm form-fit



Technical Data

Electrical data	Nominal voltage	AC 24 V, 50/60 Hz / DC 24 V	
	Nominal voltage range	AC 19.2 ... 28.8 V / DC 21.6 ... 28.8 V	
	Switching thresholds	min. ON voltage	AC 19.2 V / DC 21.6 V
		max. OFF voltage	AC 6.5 V / DC 6.5 V
	Power consumption	12 W @ nominal torque / 0.5 W @ holding	
	For wire sizing	18 VA / I _{max.} 8.2 A @ 5 ms	
	Auxiliary switch	2 x 1 SPDT	
	Contact rating (contacts gold plate on silver)	1 mA ... 6 A, DC 5 V ... AC 250 V <input type="checkbox"/>	
	Switching points	3° ↺ / 87° ↺ (referred to 0 ... 90° ↺)	
	Tolerance	±2	
Connecting cable	motor	1 m, 3 x 0.75 mm ² (halogen-free) with plug connectors, suitable for BKNE230-24	
	auxiliary switch	1 m, 6 x 0.75 mm ² (halogen-free) with plug connectors, suitable for BKNE230-24	
Functional data	Torque (nominal torque)	Min. 40 Nm @ nominal voltage	
	Blocking torque	dynamic	40 Nm
		steady-state	50 Nm
	Direction of rotation	Selected by mounting L/R	
	Angle of rotation	Max. 100° ↺ (incl. 5° ↺ mechanical overrun on each side)	
	Running time	<60 s for 90° ↺	
	Sound power level	Max. 62 dB (A)	
	Damper rotation	BE24-ST	Form-fit 14 mm
		BE24-12-ST	Form-fit 12 mm
	Position indication	Mechanical with pointer	
Service life	At least 10'000 cycles		
Working conditions	Protection class	III Safety extra-low voltage	
	Degree of protection	IP54 in all mounting positions	
	EMC	CE according to 89/336/EEC, 92/31/EEC, 93/68/EEC	
	Mode of operation	Type 1.B (according to EN60730-1)	
	Rated impulse voltage	0.8 kV (according to EN60730-1)	
	Control pollution degree	3 (according to EN60730-1)	
	Ambient temperature range	normal duty	-30 ... +50°C
		safety duty	See «Safety function» on page 2
	Non-operating temperature	-40 ... +80°C	
	Ambient humidity range	According to EN 60730-1	
Maintenance	Maintenance-free		
Dimensions / weight	Dimensions	See «Dimensions» on page 3	
	Weight	Approx. 2'700 g	

Safety notes



- The actuator is not allowed to be used outside the specified field of application, especially in aircraft or in any other airborne means of transport.
- The actuator is adapted and mounted to the fire and smoke damper by the damper manufacturer. For this reason, the actuator is only supplied direct to safety damper manufacturers. The manufacturer then bears full responsibility for the proper functioning of the damper.
- Since very high values of torque are exerted on the damper spindle it is advisable to use steel of at least grade St50.
- The device may only be opened at the manufacturer's site. It does not contain any parts that can be replaced or repaired by the user.
- The device contains electronic and electrical components and may not be disposed of with the household waste. Observe local regulations and valid laws.

Product features

Mode of operation Open-Close control is exercised via the BKNE230-24 communication and power unit.

Signalling The limit switches incorporated into the actuator signal the position of the damper to the SBSE-Control system that is monitoring it. The position of the damper blade can also be seen from a mechanical position indicator.

Manual operation The crank handle supplied with the actuator allows it to be operated manually. It also allows a functional test of the damper to be performed very easily.

Connection to SBSE-Control The actuator is fitted with plugs. In this way, it can be connected via a communication and power supply unit (see «accessories») in the SBSE-Control control and monitoring system.

Plug connectors



Direction of rotation The direction of rotation of the actuator depends on the SBSE-Control system and the plugging connections. In response to the damper OPEN command (for smoke extraction) the actuator runs to the 90° ↺ position; in response to the damper CLOSE command (for cease smoke extraction) it runs to the 0° ↺.

- Standards and specifications** The design of the actuator is based on the following standards and specifications:
- Draft DIN 18232, Part 6, Sept. 1992
 - Fire protection in industrial buildings
 - Smoke and heat extraction systems
 - Preliminary standard ÖNORM H 6029, May 1997
 - Ventilation systems
 - Fire smoke extraction systems
 - Extracts from:
 - CEN/TC191, 1996
 - prEN12101-8 (Smoke and heat control systems – Specifications for smoke control dampers)

Safety function The safety function is guaranteed within the temperature range shown in the diagram below which is based on standard ÖNORM H 6029 and DIN 18232.

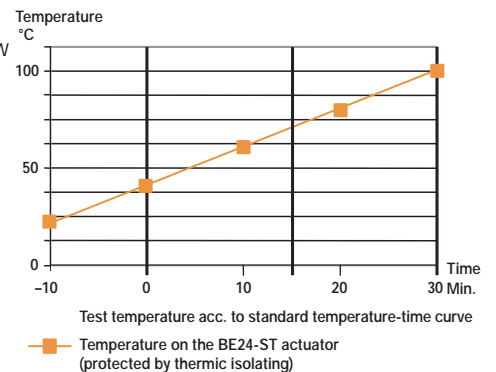

Accessories

	Description	Type
Electrical accessories Communication and power unit	Cable set with plug (L=0.5 m) for BE on BKNE230-24	ZST-BS
	For integration in the SBSE-Control network	BKNE230-24

Electrical installation

Wiring diagram Application with the SBSE-Control damper control and monitoring system

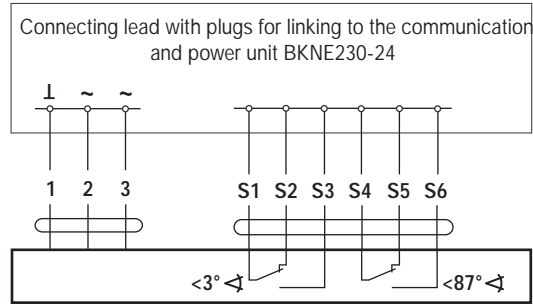

Dimensions [mm]

Dimensional diagrams

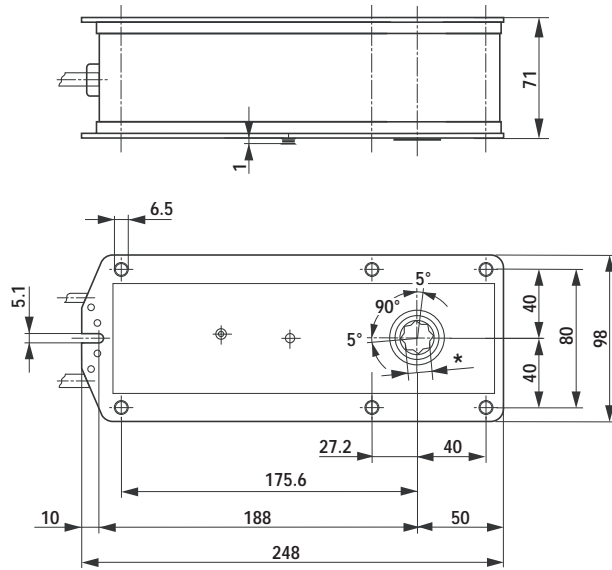

Type	Damper driver
BE24-ST	Form-fit 14.2 mm
BE24-12-ST	Form-fit 12.2 mm

Actuator for
smoke control dampers 90° ↺

- Torque 40 Nm
- Nominal voltage AC 230 V
- Control: Open/close
- Damper rotation:
BE230: 14 mm form-fit
BE230-12: 12 mm form-fit



Technical Data

Electrical data	Nominal voltage	AC 24 V, 50/60 Hz	
	Nominal voltage range	AC 198 ... 264 V	
	Switching thresholds	min. ON voltage	AC 198 V
		max. OFF voltage	AC 100 V
	Power consumption	8 W @ nominal torque / 0.5 W holding	
	For wire sizing	15 VA / I _{max} . 7.9 A @ 5 ms	
	Auxiliary switch	2 x 1 SPDT	
	Contact rating (contacts gold plate on silver)		1 mA ... 6 A, DC 5 V ... AC 250 V <input type="checkbox"/>
		Switching points	3° ↺ / 87° ↺ (referred to 0 ... 90° ↺)
	Connecting cable	motor	1 m, 3 x 0,75 mm ² (halogen-free)
auxiliary switch		1 m, 6 x 0,75 mm ² (halogen-free)	
Functional data	Torque (nominal torque)	Min. 40 Nm @ nominal voltage	
	Blocking torque	dynamic	40 Nm
		steady-state	50 Nm
	Direction of rotation	Selected by mounting L/R	
	Angle of rotation	Max. 100° ↺ (incl. 5° ↺ mechanical overrun on each side)	
	Running time	<60 s for 90° ↺	
	Sound power level	Max. 62 dB (A)	
	Damper rotation	BE230	Form-fit 14 mm
		BE230-12	Form-fit 12 mm
	Position indication	Mechanical with pointer	
Service life	At least 10'000 cycles		
Working conditions	Protection class	II totally insulated <input type="checkbox"/>	
	Degree of protection	IP54 in all mounting positions	
	EMC low-voltage directive		CE according to 89/336/EEC, 92/31/EEC, 93/68/EEC
			CE according to 73/23/EEC
	Mode of operation	Type 1.B (according to EN60730-1)	
	Rated impulse voltage	4 kV (according to EN60730-1)	
	Control pollution degree	3 (according to EN60730-1)	
	Ambient temperature range	normal duty	-30 ... +50°C
		safety duty	See «Safety function» on page 2
	Non-operating temperature	-40 ... +80°C	
Ambient humidity range	According to EN 60730-1		
Maintenance	Maintenance-free		
Dimensions / weight	Dimensions	See «Dimensions» on page 2	
	Weight	Approx. 2'700 g	

Safety notes



- The actuator is not allowed to be used outside the specified field of application, especially in aircraft or in any other airborne means of transport.
- **Caution: Power supply voltage!**
- The actuator is adapted and mounted to the fire and smoke damper by the damper manufacturer. For this reason, the actuator is only supplied direct to safety damper manufacturers. The manufacturer then bears full responsibility for the proper functioning of the damper.
- Since very high values of torque are exerted on the damper spindle it is advisable to use steel of at least grade St50.
- The device may only be opened at the manufacturer's site. It does not contain any parts that can be replaced or repaired by the user.
- The device contains electronic and electrical components and may not be disposed of with the household waste. Observe local regulations and valid laws.

Product features

- Mode of operation** Open/Close control is effected by means of a 2-wire system. The actuator is overload-proof and therefore remain energized while stationary at the end-stops.
- Signalling** Two microswitches with fixed settings are installed in the actuator for indicating the damper end positions. The position of the damper blade can be read off on a mechanical position indicator.
- Manual operation** The crank handle supplied with the actuator allows it to be operated manually. It also allows a functional test of the damper to be performed very easily.

- Standards and specifications** The design of the actuator is based on the following standards and specifications:
 - Draft DIN 18232, Part 6, Sept. 1992
 - Fire protection in industrial buildings
 - Smoke and heat extraction systems
 - Preliminary standard ÖNORM H 6029, May 1997
 - Ventilation systems
 - Fire smoke extraction systems
 - Extracts from:
 - CEN/TC191, 1996
 - prEN12101-8 (Smoke and heat control systems – Specifications for smoke control dampers)

Safety function The safety function is guaranteed within the temperature range shown in the diagram below which is based on standard ÖNORM H 6029 and DIN 18232.

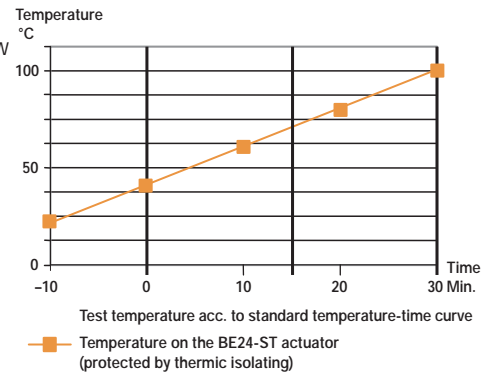

Electrical installation

Wiring diagram

Note

- Supply via safety isolation transformer
- Parallel connection of several actuators possible. Power consumption and switching thresholds must be observed!

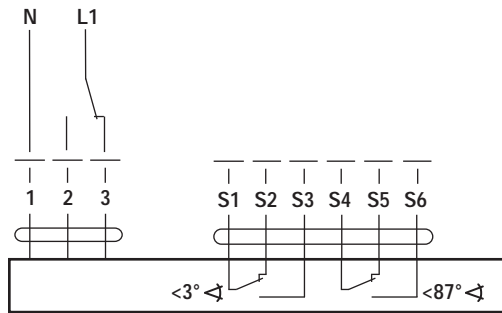

Dimensions [mm]

Dimensional diagrams

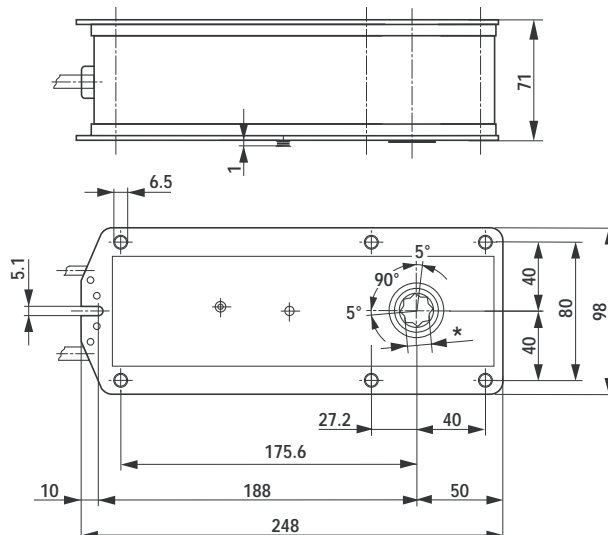

Type	Damper driver
BE230	Form-fit 14.2 mm
BE230-12	Form-fit 12.2 mm

Subject to technical changes