

Spring-return actuator for fire and smoke dampers 90°↔ in ventilation and air-conditioning systems.

- Torque 18/12 Nm
- Nominal voltage AC/DC 24 V
- Control: Open/close
- Damper rotation: 12 mm form-fit



Technical Data

Electrical data	Nominal voltage	AC 24 V, 50/60 Hz / DC 24 V		
	Nominal voltage range	AC 19.2 ... 28.8 V / DC 21.6 ... 28.8 V		
	Power consumption	motoring	7 W @ nominal torque	
		holding	2 W	
		for wire sizing	10 VA / I _{max} . 8.3 A @ 5 ms	
	Auxiliary switch	2 x 1 SPDT		
Contact rating (contacts gold plate on silver)	1 mA ... 6 A (3 A), DC 5 V ... AC 250 V <input type="checkbox"/>			
Switching points	5°↔ / 80°↔			
Connecting cable	motor	1 m, 2 x 0.75 mm ² (halogen-free)		
	auxiliary switch	1 m, 6 x 0.75 mm ² (halogen-free)		
Functional data	Torque	motor	Min. 18 Nm	
		spring-return	Min. 12 Nm	
	Direction of rotation	Selected by mounting L/R		
	Angle of rotation	Max. 95°↔ (incl. 5°↔ spring pretensioning)		
	Running time	motor	140 s	
		spring-return	~16 s (t _{amb} = 20°C)	
	Sound power level	motor	Max. 45 dB (A)	
		spring-return	~62 dB (A)	
	Damper rotation	Form-fit 12 mm (10 with adapter supplied)		
	Position indication	Mechanical with pointer		
Service life	Min. 60'000 safe positions			
Working conditions	Protection class	III Safety extra-low voltage		
	Degree of protection	IP54 in all mounting positions		
	EMC	CE according to 89/336/EEC, 92/31/EEC, 93/68/EEC		
	Mode of operation	Type 1.AA.B (according to EN60730-1)		
	Rated impulse voltage	0.8 kV (according to EN60730-1)		
	Control pollution degree	3 (according to EN60730-1)		
	Ambient temperature range	normal duty	-30 ... +50°C	
		safety duty	The safe position will be attained up to max. 75°C when initiated by a thermal trip	
	Non-operating temperature	-40 ... +80°C		
	Ambient humidity range	According to EN 60730-1		
Maintenance	Maintenance-free			
Dimensions / weight	Dimensions	See «Dimensions» on page 2		
	Weight	Approx. 2'800 g		

Safety notes



- The actuator is not allowed to be used outside the specified field of application, especially in aircraft or in any other airborne means of transport.
- The actuator is adapted and mounted to the fire and smoke damper by the damper manufacturer. For this reason, the actuator is only supplied direct to safety damper manufacturers. The manufacturer then bears full responsibility for the proper functioning of the damper.
- The device may only be opened at the manufacturer's site. It does not contain any parts that can be replaced or repaired by the user.
- The device contains electronic and electrical components and may not be disposed of with the household waste. Observe local regulations and valid laws.

Product features

- Mode of operation** The actuator moves the damper to its normal working position while tensioning the return spring at the same time. If the power supply is interrupted, the energy stored in the spring moves the damper back to its safe position.
- Signalling** Two microswitches with fixed settings are installed in the actuator for indicating the damper end positions.
The position of the damper blade can be read off on a mechanical position indicator.
- Manual operation** Without power supply, the damper can be operated manually and fixed in any required position. Release of the locking mechanism can be achieved manually or automatically by applying the supply voltage.

Accessories

	Description	Type
Electrical accessories	Thermoelectric Tripping Device	BAE72 (-F-ST)
	Thermoelectric Tripping Device with test button	BAE72-S (-F-ST)
	Auxiliary switch, 1 x SPDT 6 A (2.5 A), AC 250 V	SN1
	Auxiliary switch, 2 x SPDT 6 A (2.5 A), AC 250 V	SN2
	Cable set with plug (L=0.5 m) for BF.. and BLF.. on BKN230-24	ZST-BS
Mechanical accessories	Adapter with clamp for rotary axes up to 20 mm for BF.. and BLF..	ZK-BF
	Adapter with DM18 rotary axis, L = 33 mm, for BF.. and BLF..	ZA18-BF
	Adapter 12/8 mm for BF.. and BLF..	ZA8-BF
	Adapter 12/11 mm for BF.. and BLF..	ZA11-BF
	Bracket for SN1 and SN2 auxiliary switches for BF..	ZSN-BF

Electrical installation

Wiring diagram

Note

- Supply via safety isolation transformer
- Parallel connection of several actuators possible.

Power consumption must be observed!

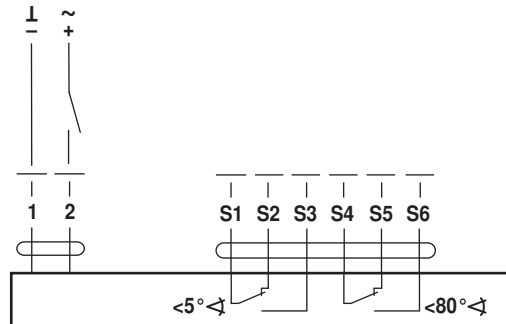

Dimensions [mm]

Dimensional diagrams

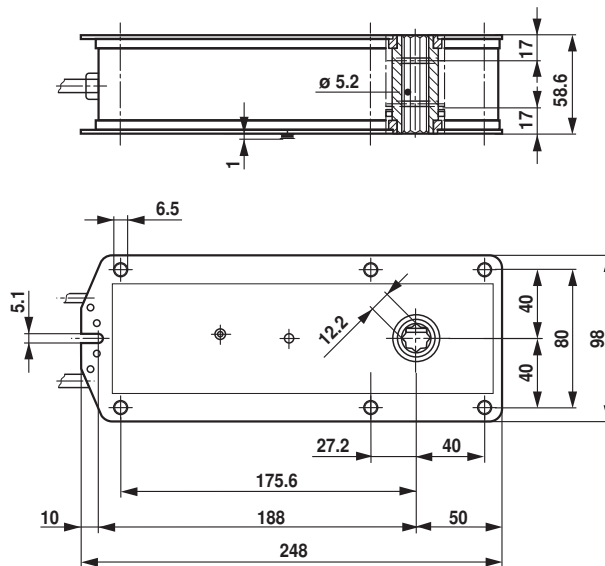

Spring-return actuator for fire and smoke dampers 90° in ventilation and air-conditioning systems, integrated in the SBS-Control control and monitoring system or in MP-Bus networks.

- Torque 18/12 Nm
- Nominal voltage AC/DC 24 V
- Control: Open/close
- Damper rotation: 12 mm form-fit

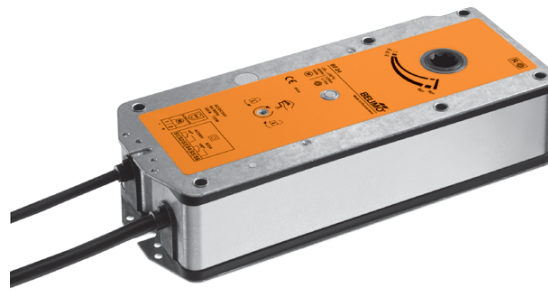
Technical Data

Electrical data	Nominal voltage	AC 24 V, 50/60 Hz / DC 24 V		
	Nominal voltage range	AC 19.2 ... 28.8 V / DC 21.6 ... 28.8 V		
	Power consumption	motoring	7 W @ nominal torque	
		holding	2 W	
		for wire sizing	10 VA / I _{max} : 8.3 A @ 5 ms	
	Auxiliary switch	2 x 1 SPDT		
	Contact rating (contacts gold plate on silver)	1 mA ... 6 A (3 A), DC 5 V ... AC 250 V <input type="checkbox"/>		
Switching points	5° / 80°			
Connecting cable	motor	1 m, 2 x 0.75 mm ² (halogen-free) with plug connectors, suitable for BKN230-24		
	auxiliary switch	1 m, 6 x 0.75 mm ² (halogen-free) with plug connectors, suitable for BKN230-24		
Functional data	Torque	motor	Min. 18 Nm	
		spring-return	Min. 12 Nm	
	Direction of rotation	Selected by mounting L/R		
	Angle of rotation	Max. 95° (incl. 5° spring pretensioning)		
	Running time	motor	140 s	
		spring-return	~16 s (t _{amb} = 20 °C)	
	Sound power level	motor	Max. 45 dB (A)	
		spring-return	~62 dB (A)	
	Damper rotation	Form-fit 12 mm (10 mm with adapter supplied)		
	Position indication	Mechanical with pointer		
Service life	Min. 60'000 safe positions			
Working conditions	Protection class	III Safety extra-low voltage		
	Degree of protection	IP54 in all mounting positions		
	EMC	CE according to 89/336/EEC, 92/31/EEC, 93/68/EEC		
	Mode of operation	Type 1.AA.B (according to EN60730-1)		
	Rated impulse voltage	0.8 kV (according to EN60730-1)		
	Control pollution degree	3 (according to EN60730-1)		
	Ambient temperature range	normal duty	-30 ... +50 °C	
		safety duty	The safe position will be attained up to max. 75 °C when initiated by a thermal trip	
	Non-operating temperature	-40 ... +80 °C		
	Ambient humidity range	According to EN 60730-1		
Maintenance	Maintenance-free			
Dimensions / weight	Dimensions	See «Dimensions» on page 2		
	Weight	Approx. 2'800 g		

Safety notes

- The actuator is not allowed to be used outside the specified field of application, especially in aircraft or in any other airborne means of transport.
- The actuator is adapted and mounted to the fire and smoke damper by the damper manufacturer. For this reason, the actuator is only supplied direct to safety damper manufacturers. The manufacturer then bears full responsibility for the proper functioning of the damper.
- The device may only be opened at the manufacturer's site. It does not contain any parts that can be replaced or repaired by the user.
- The device contains electronic and electrical components and may not be disposed of with the household waste. Observe local regulations and valid laws.

Product features

- Mode of operation** The actuator moves the damper to its normal working position while tensioning the return spring at the same time. If the power supply is interrupted, the energy stored in the spring moves the damper back to its safe position.
- Signalling** Two microswitches with fixed settings are installed in the actuator for indicating the damper end positions. The position of the damper blade can be read off on a mechanical position indicator.
- Manual operation** Without power supply, the damper can be operated manually and fixed in any required position. Release of the locking mechanism can be achieved manually or automatically by applying the supply voltage.
- Connection to SBS-Control** The actuator is fitted with plugs. In this way, it can be connected via a communication and power supply unit (see «accessories») in the SBS-Control control and monitoring system or in MP-Bus networks.

Plug connectors



Accessories

	Description	Type
Electrical accessories	Thermoelectric Tripping Device	BAE72 (-F-ST)
	Thermoelectric Tripping Device with test button	BAE72-S (-F-ST)
Communication and power units	Auxiliary switch, 1 x SPDT 6 A (2.5 A), AC 250 V	SN1
	Auxiliary switch, 2 x SPDT 6 A (2.5 A), AC 250 V	SN2
	Cable set with plug (L=0.5 m) for BF.. and BLF.. on BKN230-24	ZST-BS
	For integration in the SBS-Control control system	BKN230-24
Mechanical accessories	For integration in the SBS-Control control system and MP-Bus networks	BKN230-24-1MP
	Adapter with clamp for rotary axes up to 20 mm for BF.. and BLF..	ZK-BF
	Adapter with DM18 rotary axis, L = 33 mm, for BF.. and BLF..	ZA18-BF
	Adapter 12/8 mm for BF.. and BLF..	ZA8-BF
	Adapter 12/11 mm for BF.. and BLF..	ZA11-BF
	Bracket for SN1 and SN2 auxiliary switches for BF..	ZSN-BF

Electrical installation

Wiring diagram Application with the SBS-Control damper control and monitoring system

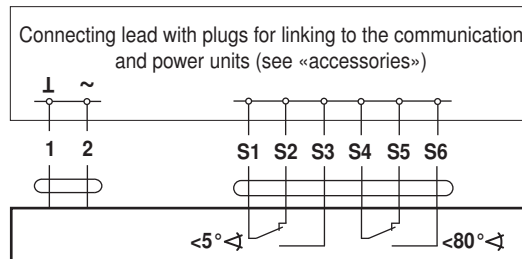

Dimensions [mm]

Dimensional diagrams

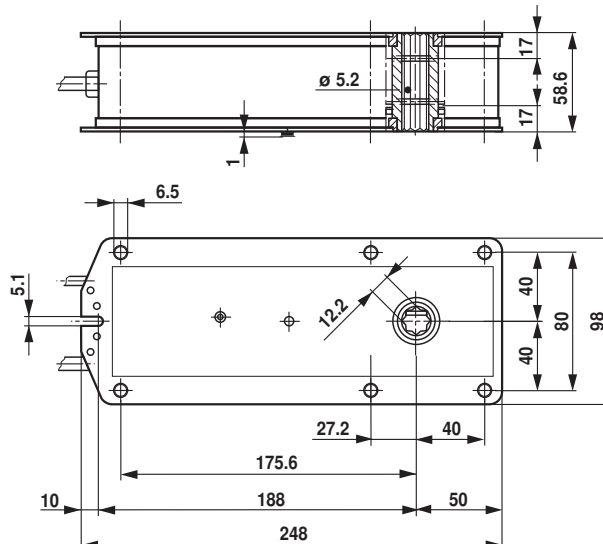

Spring-return actuator, combined with thermo-electric tripping device (72 °C), for fire and smoke dampers 90° in ventilation and air-conditioning systems.

- Torque 18/12 Nm
- Nominal voltage AC/DC 24 V
- Control: Open/close
- Damper rotation: 12 mm form-fit

Technical Data

Electrical data	Nominal voltage	AC 24 V, 50/60 Hz / DC 24 V		
	Nominal voltage range	AC 19.2 ... 28.8 V / DC 21.6 ... 28.8 V		
	Power consumption	motoring	7 W @ nominal torque	
		holding	2 W	
		for wire sizing	10 VA / I _{max} . 5.8 A @ 5 ms	
	Auxiliary switch	2 x 1 SPDT		
	Contact rating (contacts gold plate on silver)	1 mA ... 6 A (3 A), DC 5 V ... AC 250 V <input type="checkbox"/>		
	Switching points	5° / 80°		
	Thermal trips	Tf1: duct outside temperature 72 °C Tf2 + Tf3: duct inside temperature 72 °C		
	Connecting cable	motor	1 m, 2 x 0.75 mm ² (halogen-free)	
auxiliary switch		1 m, 6 x 0.75 mm ² (halogen-free)		
Functional data	Torque	motor	Min. 18 Nm	
		spring-return	Min. 12 Nm	
	Direction of rotation	Selected by mounting L/R		
	Angle of rotation	Max. 95° (incl. 5° spring pretensioning)		
	Running time	motor	140 s	
		spring-return	~16 s (t _{amb} = 20 °C)	
	Sound power level	motor	Max. 45 dB (A)	
		spring-return	~62 dB (A)	
	Damper rotation	Form-fit 12 mm (10 mm with adapter supplied)		
	Position indication	Mechanical with pointer		
Service life	Min. 60'000 safe positions			
Working conditions	Protection class	III Safety extra-low voltage		
	Degree of protection	IP54 in all mounting positions		
	EMC	CE according to 89/336/EEC, 92/31/EEC, 93/68/EEC		
	Mode of operation	Type 1.AA.B (according to EN60730-1)		
	Rated impulse voltage	0.8 kV (according to EN60730-1)		
	Control pollution degree	3 (according to EN60730-1)		
	Ambient temperature range	normal duty	-30 ... +50 °C	
		safety duty	The safe position will be attained up to max. 75 °C	
	Non-operating temperature	-40 ... +50 °C		
	Ambient humidity range	According to EN 60730-1		
Maintenance	Maintenance-free			
Dimensions / weight	Dimensions	See «Dimensions» on page 2		
	Weight	Approx. 2'800 g		

Safety notes

- The actuator is not allowed to be used outside the specified field of application, especially in aircraft or in any other airborne means of transport.
- The actuator is adapted and mounted to the fire and smoke damper by the damper manufacturer. For this reason, the actuator is only supplied direct to safety damper manufacturers. The manufacturer then bears full responsibility for the proper functioning of the damper.
- The device may only be opened at the manufacturer's site. It does not contain any parts that can be replaced or repaired by the user.
- The device contains electronic and electrical components and may not be disposed of with the household waste. Observe local regulations and valid laws.

Product features

Mode of operation The actuator moves the damper to its normal working position while tensioning the return spring at the same time. If the power supply is interrupted, the energy stored in the spring moves the damper back to its safe position.

Thermo-electric tripping device BAE72B-S Thermal trip Tf1 operates if the ambient temperature exceeds 72°C. Replaceable thermal trip Tf2/Tf3 operates if the temperature inside the duct exceeds 72°C. Tf1, Tf2 or Tf3 trips cause the power supply to be interrupted permanently so that it cannot be uncanceled.

Note
The function of the thermal trip and the test switch is only warranted if the actuator is connected to the power supply and has reached its operating position.

The LED is lit when
– there is a supply voltage,
– the temperature fuses are OK and
– the test switch is not pressed.

Signalling Two microswitches with fixed settings are installed in the actuator for indicating the damper end positions. The position of the damper blade can be read off on a mechanical position indicator.

Manual operation Without power supply, the damper can be operated manually and fixed in any required position. Release of the locking mechanism can be achieved manually or automatically by applying the supply voltage.

Accessories

	Description	Type
Electrical accessories	Auxiliary switch, 1 x PDT 6 A (2.5 A), AC 250 V	SN1
	Auxiliary switch, 2 x PDT 6 A (2.5 A), AC 250 V	SN2
	Cable set with plug (L=0.5 m) for BF.. and BLF.. on BKN230-24	ZST-BS
	Blanking cover (without canal sensor function)	ZBAE0
	Spare thermoelectric tripping device. Duct inside temperature 72°C	ZBAE72
	Spare thermoelectric tripping device. Duct inside temperature 95°C, colour green	ZBAE95
Mechanical accessories	Adapter with clamp for rotary axes up to 20 mm for BF.. and BLF..	ZK-BF
	Adapter with DM18 rotary axis, L = 33 mm, for BF.. and BLF..	ZA18-BF
	Adapter 12/8 mm for BF.. and BLF..	ZA8-BF
	Adapter 12/11 mm for BF.. and BLF..	ZA11-BF
	Bracket for SN1 and SN2 auxiliary switches for BF..	ZSN-BF

Electrical installation

Wiring diagram

Note
• Supply via safety isolation transformer
• Parallel connection of several actuators possible. Power consumption must be observed!

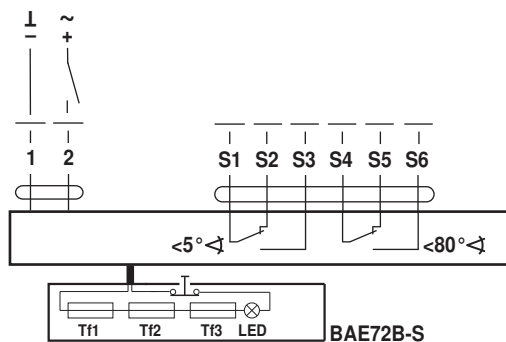

Dimensions [mm]

Dimensional diagrams

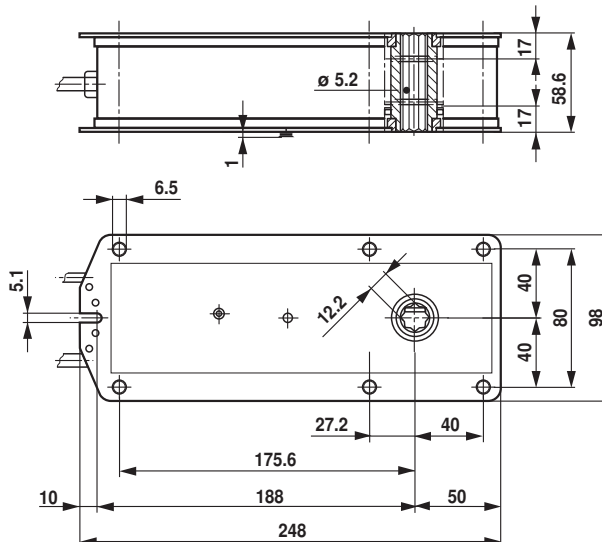

Spring-return actuator, combined with thermo-electric tripping device (72 °C), for fire and smoke dampers 90° ↺ in ventilation and air-conditioning systems, integrated in the SBS-Control control and monitoring system or in MP-Bus networks.

- Torque 18/12 Nm
- Nominal voltage AC/DC 24 V
- Control: Open/close
- Damper rotation: 12 mm form-fit

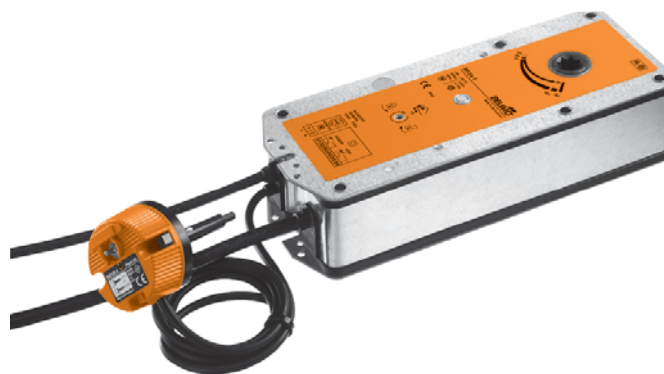

Technical Data

Electrical data	Nominal voltage	AC 24 V, 50/60 Hz / DC 24 V		
	Nominal voltage range	AC 19.2 ... 28.8 V / DC 21.6 ... 28.8 V		
	Power consumption	motoring	7 W @ nominal torque	
		holding	2 W	
		for wire sizing	10 VA / I _{max} . 5.8 A @ 5 ms	
	Auxiliary switch	2 x 1 SPDT		
	Contact rating (contacts gold plate on silver)	1 mA ... 6 A (3 A), DC 5 V ... AC 250 V <input type="checkbox"/>		
	Switching points	5° ↺ / 80° ↺		
	Thermal trips	Tf1: duct outside temperature 72 °C Tf2 + Tf3: duct inside temperature 72 °C		
	Connecting cable	motor	1 m, 2 x 0.75 mm ² (halogen-free) with plug connectors, suitable for BKN230-24	
auxiliary switch		1 m, 6 x 0.75 mm ² (halogen-free) with plug connectors, suitable for BKN230-24		
Functional data	Torque	motor	Min. 18 Nm	
		spring-return	Min. 12 Nm	
	Direction of rotation	Selected by mounting L/R		
	Angle of rotation	Max. 95° ↺ (incl. 5° ↺ spring pretensioning)		
	Running time	motor	140 s	
		spring-return	~16 s (t _{amb} = 20 °C)	
	Sound power level	motor	Max. 45 dB (A)	
		spring-return	~62 dB (A)	
	Damper rotation	Form-fit 12 mm (10 mm with adapter supplied)		
	Position indication	Mechanical with pointer		
Service life	Min. 60'000 safe positions			
Working conditions	Protection class	III Safety extra-low voltage		
	Degree of protection	IP54 in all mounting positions		
	EMC	CE according to 89/336/EEC, 92/31/EEC, 93/68/EEC		
	Mode of operation	Type 1.AA.B (according to EN60730-1)		
	Rated impulse voltage	0.8 kV (according to EN60730-1)		
	Control pollution degree	3 (according to EN60730-1)		
	Ambient temperature range	normal duty	-30 ... +50 °C	
		safety duty	The safe position will be attained up to max. 75 °C	
	Non-operating temperature	-40 ... +50 °C		
	Ambient humidity range	According to EN 60730-1		
Maintenance	Maintenance-free			
Dimensions / weight	Dimensions	See «Dimensions» on page 2		
	Weight	Approx. 2'800 g		

Safety notes



- The actuator is not allowed to be used outside the specified field of application, especially in aircraft or in any other airborne means of transport.
- The actuator is adapted and mounted to the fire and smoke damper by the damper manufacturer. For this reason, the actuator is only supplied direct to safety damper manufacturers. The manufacturer then bears full responsibility for the proper functioning of the damper.
- The device may only be opened at the manufacturer's site. It does not contain any parts that can be replaced or repaired by the user.
- The device contains electronic and electrical components and may not be disposed of with the household waste. Observe local regulations and valid laws.

Product features

Mode of operation The actuator moves the damper to its normal working position while tensioning the return spring at the same time. If the power supply is interrupted, the energy stored in the spring moves the damper back to its safe position.

Thermo-electric tripping device BAE72B-S Thermal trip Tf1 operates if the ambient temperature exceeds 72°C. Replaceable thermal trip Tf2/Tf3 operates if the temperature inside the duct exceeds 72°C. Tf1, Tf2 or Tf3 trips cause the power supply to be interrupted permanently so that it cannot be uncanceled.

Note
The function of the thermal trip and the test switch is only warranted if the actuator is connected to the power supply and has reached its operating position.

The LED is lit when
– there is a supply voltage,
– the temperature fuses are OK and
– the test switch is not pressed.

Signalling Two microswitches with fixed settings are installed in the actuator for indicating the damper end positions.

Manual operation The position of the damper blade can be read off on a mechanical position indicator. Without power supply, the damper can be operated manually and fixed in any required position. Release of the locking mechanism can be achieved manually or automatically by applying the supply voltage.

Connection to SBS-Control The actuator is fitted with plugs. In this way, it can be connected via a communication and power supply unit (see «accessories») in the SBS-Control control and monitoring system or in MP-Bus networks.



Accessories

	Description	Type
Electrical accessories	Auxiliary switch, 1 x PDT 6 A (2.5 A), AC 250 V	SN1
	Auxiliary switch, 2 x PDT 6 A (2.5 A), AC 250 V	SN2
	Cable set with plug (L=0.5 m) for BF.. and BLF.. on BKN230-24	ZST-BS
	Blanking cover (without canal sensor function)	ZBAE0
	Spare thermoelectric tripping device. Duct inside temperature 72°C	ZBAE72
Communication and power units	Spare thermoelectric tripping device. Duct inside temperature 95°C, colour green	ZBAE95
	For integration in the SBS-Control control system	BKN230-24
Mechanical accessories	For integration in the SBS-Control control system and MP-Bus networks	BKN230-24-1MP
	Adapter with clamp for rotary axes up to 20 mm for BF.. and BLF..	ZK-BF
	Adapter with DM18 rotary axis, L = 33 mm, for BF.. and BLF..	ZA18-BF
	Adapter 12/8 mm for BF.. and BLF..	ZA8-BF
	Adapter 12/11 mm for BF.. and BLF..	ZA11-BF
	Bracket for SN1 and SN2 auxiliary switches for BF..	ZSN-BF

Electrical installation

Wiring diagram Application with the SBS-Control damper control and monitoring system

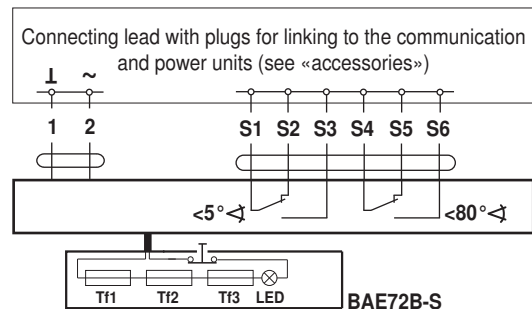

Dimensions [mm]

Dimensional diagrams

