

Damper Actuators

Spring Return AFR... series



Technical Databook



Spring return actuator	TF..	LF..	NF..	AF..	AFR..
ON/OFF	2 Nm	4 Nm	7 Nm	15Nm	15Nm
AC 24 V 50/60 Hz, DC 24 V	TF24	LF24-S	NF24**	AF24	AFR24
Auxiliary switch build-in 1 x SPDT	TF24-S	LF24-S			AFR24-S
Auxiliary switch build-in 2 x SPDT			NF24-S**	AF24-S	
AC 230 V 50/60 Hz	TF230	LF230	NF230	AF230	AFR230
Auxiliary switch build-in 1 x SPDT	TF230-S	LF230-S			AFR230-S
Auxiliary switch build-in 2 x SPDT			NF230-S	AF230-S	
3-point	TF24-3	LF24-3*			
Modulating					
AC 24 V 50/60 Hz, DC 24 V					
Control signal DC 2(0)..10V, feedback DC 2..10V	TF24-SR	LF24-SR	NF24-SR	AF24-SR	AFR24-SR
Running time -motor	<75s *	40-75 s *	~150 s	~150 s	
-spring return	<25s	~20 s	~ 60 s	~16 s	
Shaft diameter	6...12 mm	8...16 mm	10...20 mm	10...20 mm	10...20 mm
Sound power level -motor		Max. 50 dB(A)	Max. 55 dB(A)	Max. 45 dB(A)	Max. 45 dB(A)
-spring return		62 dB(A)	62 dB(A)	62 dB(A)	62 dB(A)
Electrical connection	Cable 1 m				
Direction of rotation	Selected by mounting L/R				
Angle of rotation	Max. 95°				
Mechanical limiter	YES				
Service life	>60,000 full cycles				
Position indicator	YES				
Degree of protection	IP42	IP54			
EMC	CE according to 89/336/EEC				
Ambient temperature	-30°C ... +50°C				
Non-operation temperature	-40°C ... +80°C				

* LF24-3 and all -SR types are 150 s.

** NF24(-S) running time -motor 75 s, -spring return 60 s.

Note:

Using Belimo Damper actuators:

- The actuators listed in this catalogue are intended for the operation of air dampers in HVAC systems.
- The damper actuator is not allowed to be used outside the specified field of application, especially in aircraft.
- The enclosure of the actuator equipment may only be opened by the manufacturer. It contains no components which the user can replace or repair.
- The device contains electrical and electronic components and is not allowed to be disposed of as household refuse. All locally valid regulations and requirements must be observed.

Torque requirements:

- When calculating the torque required to operate dampers, it is essential to take into account all the data supplied by the damper manufacturer concerning cross sectional area, design, mounting and air flow condition.

Spring return AFR.. actuators

AFR24(-S)	3
AFR24-SR	4
AFR230(-S)	5
Wiring diagrams	6
Auxiliary switch adjustment	7



- For operation of air control dampers that perform safety function
- Torque 15 Nm
- Nominal voltage AC/DC 24 V
- 1 wire control
- Integrated auxiliary switch (AFR24-S)

Technical data

Electrical data	Nominal voltage	AC 24 V 50/60 Hz, DC 24 V
	Power supply range	AC 19.2 ... 28.8 V DC 21.6 ... 26.4 V
	Power consumption	5 W @ running / 1.5 W @ holding
	Wire/transformer sizing	10 VA
	Auxiliary switch AFR24-S	1 x SPDT, 6 (3) A, AC 250 V 0 ... 89% adjustable
	Connection cable - Motor - Auxiliary switch AFR24-S	Cable 1 m, 2 x 0.75 mm ² Cable 1 m, 3 x 0.75 mm ²
Functional data	Torque - Motor - Spring return	15 Nm @ nominal voltage 15 Nm
	Direction of rotation	Selectable by L/R switch
	Angle of rotation	Max. 95° 33...100% adjustable by rotation limiter ZDB-AF - optional
	Running time - Motor - Spring return	<150 s <16 s
	Sound power level	Motor max. 45 dB (A), Spring approx. 62 dB (A)
	Position indication	Mechanical
Working conditions	Service life	> 60,000 full cycles
	Protection class	III (safety extra-low voltage)
	Degree of protection	IP54
	EMC	CE according to 89/336/EEC, 92/31/EEC, 93/68/EEC
	Low Voltage Directive	CE according to 73/23/EEC
	Ambient temperature range	-30 ... +50°C
Dimensions / weight	Non-operation temperature	-40 ... +80°C
	Humidity test	EN 60335-1
	Maintenance	Maintenance free
	Dimensions (L x W x H)	248 x 98 x 78 mm
	Shaft length	Clamp up: Min. 95 mm Clamp down: Min. 20 mm
	Shaft diameter	10 ... 19 mm
Weight	3000 g	

Dimensions [mm]

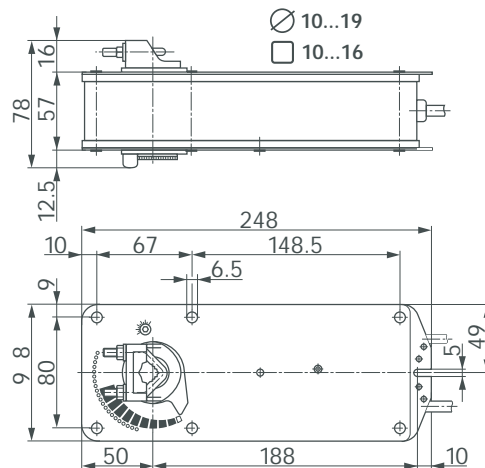

- For the operation of air dampers that perform safety functions
- Torque 15 Nm
- Nominal voltage AC/DC 24 V
- Control signal DC 2(0) ... 10 V
- Position feedback DC 2 ... 10 V



Technical data

Electrical data	Nominal voltage	AC 24 V 50/60 Hz, DC 24 V		
	Power supply range	AC	19.2 ... 28.8 V	
		DC	21.6 ... 28.8 V	
	Power consumption	6 W @ running / 2.5 W @ holding		
Functional data	Wire/transformer sizing	10 VA		
	Connection cable	Cable 1 m, 4 x 0.75 mm ²		
	Torque - Motor	15 Nm @ nominal voltage		
		- Spring return	15 Nm	
	Control signal	2(0) ... 10 VDC, input impedance 100 kΩ		
	Operating range	2 ... 10 VDC		
	Measuring voltage	2 ... 10VDC @ max. 0.5 mA (for 0...100%)		
	Direction of rotation	Motor	Selectable by L/R switch	
		Spring return	Selectable by mounting L/R	
	Angle of rotation	Max. 95° (33-100% adjustable by rotation limiter ZDB-AF - optional)		
Working conditions	Running time	- Motor	<150 s	
		- Spring return	<60 s	
	Sound power level	Motor max. 45 dB (A), Spring approx. 62 dB (A)		
	Position indication	Mechanical		
	Service life	> 60,000 full cycles		
	Protection class	III (safety extra-low voltage)		
		Degree of protection	IP54	
	EMC	CE according to 89/336/EEC, 92/31/EEC, 93/68/EEC		
	Ambient temperature range	-30 ... +50°C		
	Non-operation temperature	-40 ... +80°C		
Humidity test	95% RH, non condensing (EN 60335-1)			
Maintenance	Maintenance free			
Dimensions / weight	Dimensions (L x W x H)	248 x 98 x 78 mm		
	Shaft length	Clamp up	Min. 95 mm	
		Clamp down	Min. 20 mm	
	Shaft diameter	10 ... 19 mm		
	Weight	2700 g		

Dimensions [mm]

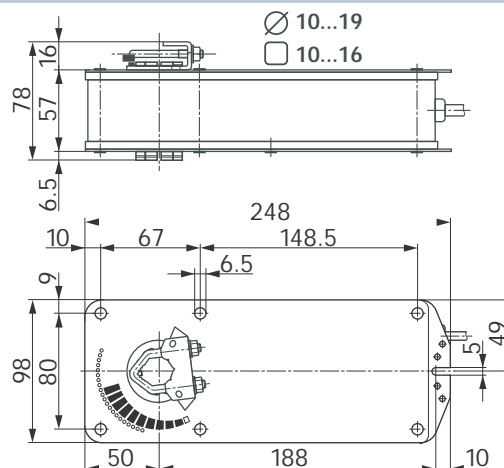



- For the operation of air dampers that perform safety functions
- Torque 15 Nm
- Nominal voltage AC 230 V
- 1 wire control
- Integrated auxiliary switch(AFR230-S)

Technical data

Electrical data	Nominal voltage	AC 230 50/60 Hz	
	Power supply range	AC 198 ... 264 V	
	Power consumption	6.5 W @ running / 2.5 W @ holding	
	Wire/transformer sizing	11 VA	
	Auxiliary switch AFR230-S	1 x SPDT, 6 (3) A, AC 250 V 0 ... 89% adjustable	
Functional data	Connection cable - Motor - Auxiliary switch AFR230-S	Cable 1 m, 2 x 0.75 mm ² Cable 1 m, 3 x 0.75 mm ²	
	Torque - Motor - Spring return	15 Nm @ nominal voltage 15 Nm	
	Direction of rotation	Selectable by mounting L/R	
	Angle of rotation	Max. 95° (33-100% adjustable by rotation limiter ZDB-AF - optional)	
	Running time - Motor - Spring return	<150 s <16 s	
	Sound power level	Motor max. 45 dB (A), Spring approx. 62 dB (A)	
	Position indication	Mechanical	
	Service life	> 60,000 full cycles	
	Working conditions	Protection class	II (all insulated)
		Degree of protection	IP54
EMC		CE according to 89/336/EEC, 92/31/EEC, 93/68/EEC	
Low Voltage Directive		CE according to 73/23/EEC	
Ambient temperature range		-30 ... +50°C	
Non-operation temperature		-40 ... +80°C	
Humidity test		EN 60335-1	
Dimensions / weight	Maintenance	Maintenance free	
	Dimensions (L x W x H)	248 x 98 x 78 mm	
	Shaft length	Clamp up Min. 95 mm Clamp down Min. 20 mm	
	Shaft diameter	10 ... 19 mm	
	Weight	3000 g	

Dimensions [mm]

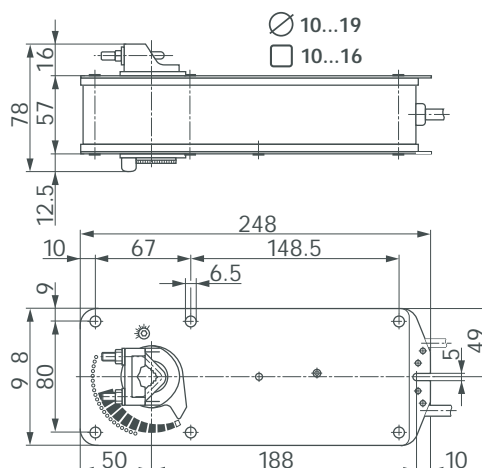

Wiring diagram: AFR..

Notes:

- Connection via safety isolating transformer!
- Parallel connection of several actuator is possible.
- Power consumption must be observed.

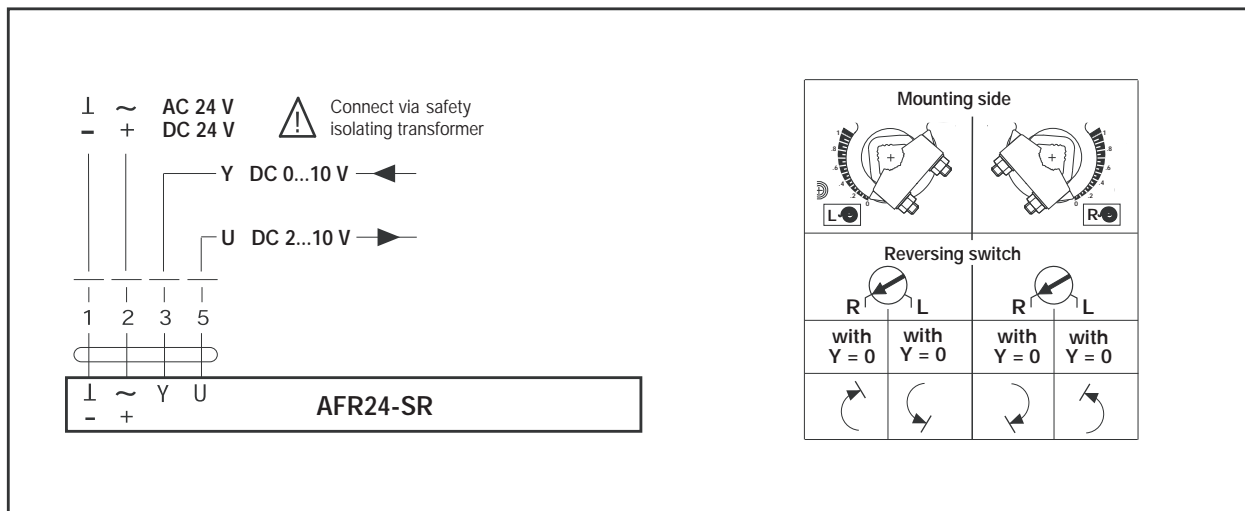
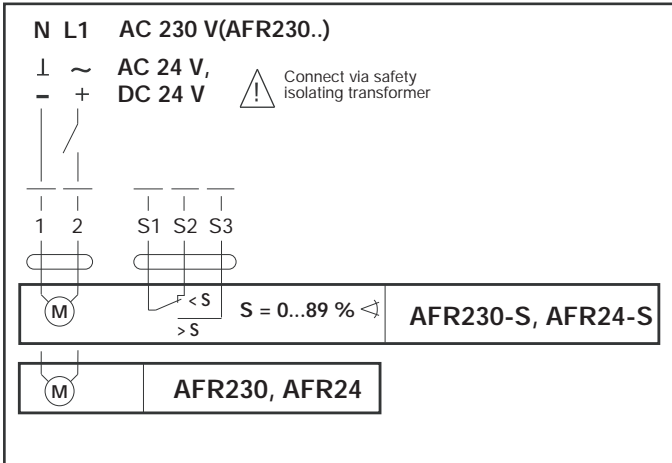

Auxiliary switch adjustment for Spring Return actuators

LF..-S (Mounting side R)

Starting point: Actuator in safe position

Procedure

- Turn the knob of the auxiliary switch until the tip of the arrow is pointing to the required switching position (see right).
Example: Switching point setting = .4 corresponds to 40% angle of rotation.
- When the actuator runs to the operating position (ccw ↺), the switch knob will also rotate counter-clockwise (ccw ↺) and the auxiliary switch will operate as the tip of the arrow passes the scale zero (S1-S3 linked).

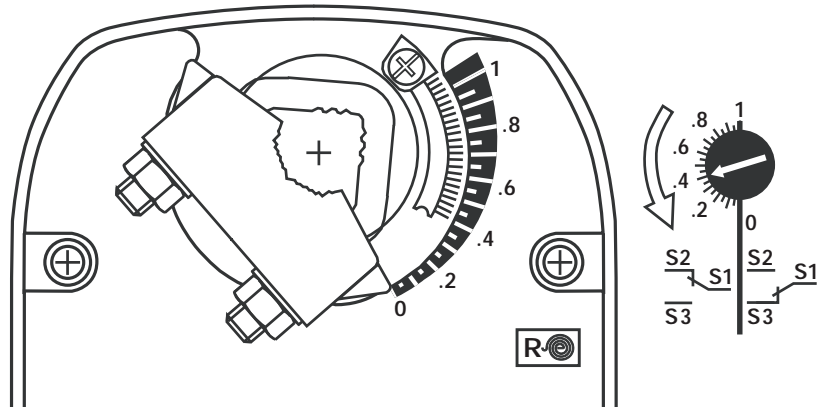

LF..-S (Mounting side L)

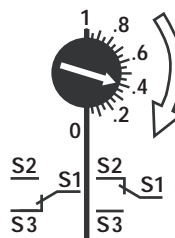
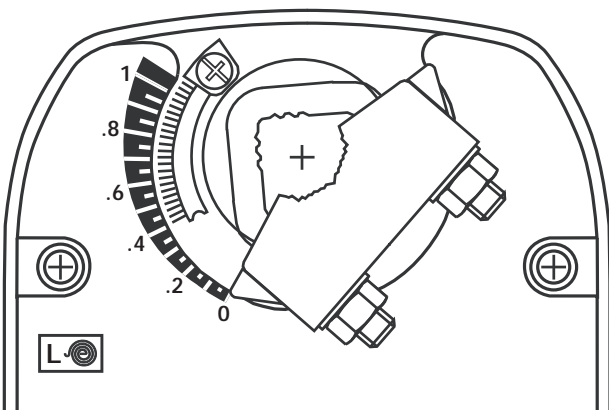

Starting point: Actuator in safe position

Procedure

- Turn the knob of the auxiliary switch until the tip of the arrow is pointing to the required switching position (see left).
Example: Switching point setting = .4 corresponds to 40% angle of rotation.
- When the actuator runs to the operating position (cw ↻), the switch knob will also rotate clockwise (cw ↻) and the auxiliary switch will operate as the tip of the arrow passes the scale zero (S1-S3 linked).

Innovation, Quality and Consultancy: A partnership for motorizing HVAC actuators



5 year warranty



On site around the globe



A complete range of products from one source



Tested quality



Short delivery times



Comprehensive support

www.belimo.com

Belimo regional head offices

EU BELIMO Automation AG
Brunnenbachstrasse 1
8340 Hinwil, Switzerland
Tel: + 41 43 843 61 11
Fax: + 41 43 843 62 68
E-Mail: info@belimo.ch

AP BELIMO Actuators (Shanghai) Trading Ltd.
No.479 Chun Dong Road, Building C-2, Xin Zhuang Industry Park
Shanghai 201108, P.R.China
Tel: + 86 21 5483 2929
Fax: + 86 21 5483 2930
www.belimo.com

US BELIMO Aircontrols (USA), Inc.
43 Old Ridgebury Road
Danbury, CT 06813-2928, USA
Tel: + 800 543-9039 / 203 791-9915
Fax: + 800 228-8283 / 203 791-9919

93010-00069

BELIMO[®]

Or contact your nearest Sales Representative