



p004/0707

Air-volume controller for static differential pressure sensor VFP...

Control input
DC 0...10 V, 0...20 V phasecut

Application

The VAV-Universal VRP forms together with the static pressure sensor VFP-... and the ...-24-V actuators a closed control loop for the pressure-independent air flow control of VAV boxes.

Thanks to the static pressure sensor, the unit can also be used for the control of contaminated and slightly aggressive air. Since it can be combined with many different types of actuators, the VRP can be used with different sizes of dampers.

Operation and adjustment

The VRP is controlled with a reference signal of DC 0...10 V (w1) or 0...20 V phasecut (w2).

The parameters \dot{V}_{MIN} and \dot{V}_{MAX} are set by means of the appropriate potentiometers.

Static pressure sensors

VFP-100 (0...100 Pa), VFP-300 (0...300 Pa)
VFP-600 (0...600 Pa)

Damper actuators

NM24-V, SM24-V, AM24-V, GM24-V,
LF24-V, AF24-V

Important

The manufacturer of the VAV boxes (i. e. the OEM) is responsible for the proper assembly and correct adjustment of the VRP and the total accuracy of the VAV boxes.

Wiring diagram

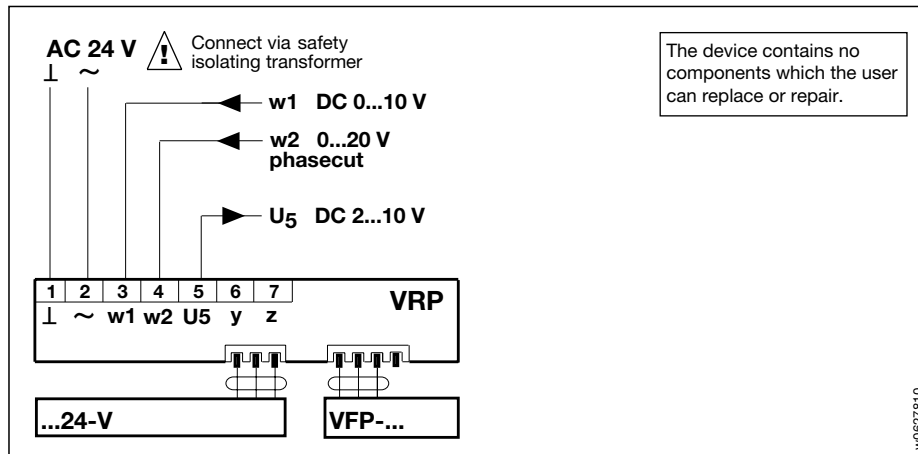

w0627/810

Technical data	VRP
Nominal voltage	AC 24 V 50/60 Hz
Nominal voltage range	AC 19.2...28.8 V
Power consumption	1.3 W (incl. sensor VFP-..., without damper actuator)
For wire sizing	2.6 VA (incl. sensor VFP-..., without damper actuator)
Reference value w1	DC 0...10 V @ input resistance 100 kΩ
Reference value w2	0...20 V phasecut @ input resistance 8 kΩ (Reference in the range between \dot{V}_{MIN} and \dot{V}_{MAX})
Operating range	DC 2...10 V
Actual-value signal for volumetric flow U5	DC 2...10 V @ 0.5 mA Signal, linear, corresponds to 0...100% \dot{V}_{NOM}
Adjusting ranges	
• \dot{V}_{MAX} (max. volumetric flow)	30...100% of adjusted reference value (\dot{V}_{NOM})
• \dot{V}_{MIN} (min. volumetric flow)	0...80% of adjusted \dot{V}_{MAX}
Connection	Screw terminals for 2 × 1.5 mm ²
Protection class	III safety extra-low voltage
Degree of protection	IP40
Ambient temperature range	0...+50 °C
Storage temperature range	-20...+80 °C
Humidity test	to EN 60730-1
EMC	CE according to 89/336/EEC
Mode of operation	Type 1 (EN 60730-1)
Weight	approx. 400 g (without pressure sensor)

Dimensions

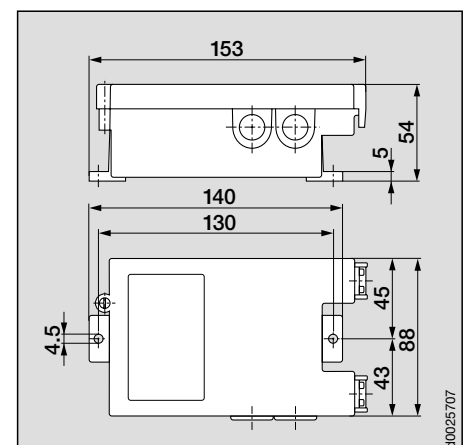

d0025707